

### General Description

Ideal for space critical applications, the LM4040 and LM4041 precision voltage references are available in the subminiature (3mm × 1.3mm) SOT-23 surface-mount package.

The LM4040 is available in fixed reverse breakdown voltages of 2.500V, 4.096V and 5.000V. The LM4041 is available with a fixed 1.225V or an adjustable reverse breakdown voltage.

The minimum operating current ranges from 60µA for the LM4041-1.2 to 74µA for the LM4040-5.0. LM4040 versions have a maximum operating current of 15mA. LM4041 versions have a maximum operating current of 12mA.

The LM4040 and LM4041 have bandgap reference temperature drift curvature correction and low dynamic impedance, ensuring stable reverse breakdown voltage accuracy over a wide range of operating temperatures and currents.

Data sheets and support documentation can be found on Micrel's web site at [www.micrel.com](http://www.micrel.com).

### Features

- Small SOT-23 package
- No output capacitor required
- Tolerates capacitive loads
- Fixed reverse breakdown voltages of 1.225, 2.500V, 4.096V and 5.000V
- Adjustable reverse breakdown version
- Contact Micrel for parts with extended temperature range.

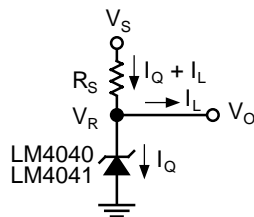
### Key Specifications

- Output voltage tolerance ..... ±0.1% (max)
- Low output noise (10Hz to 100Hz)
  - LM4040 ..... 35µV<sub>RMS</sub> (typ)
  - LM4041 ..... 20µV<sub>RMS</sub> (typ)
- Wide operating current range
  - LM4040 ..... 60µA to 15mA
  - LM4041 ..... 60µA to 12mA
- Industrial temperature range ..... -40°C to +85°C
- Low temperature coefficient ..... 100ppm/°C (max)

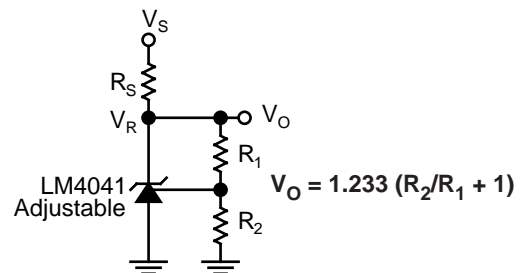
### Applications

- Battery-powered equipment
- Data acquisition systems
- Instrumentation
- Process control
- Energy management
- Product testing
- Automotive electronics
- Precision audio components

### Typical Applications

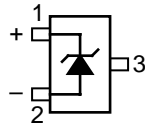


**Figure 1. LM4040, LM4041 Fixed Shunt Regulator Application**



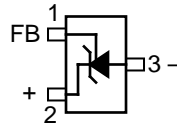
**Figure 2. LM4041 Adjustable Shunt Regulator Application**

## Pin Configuration



Pin 3 must float or  
be connected to pin 2.

**Fixed Version  
SOT-23 (M3) Package  
Top View**



**Adjustable Version  
SOT-23 (M3) Package  
Top View**

## Ordering Information

Part Number	Voltage	Accuracy, Temp. Coefficient
LM4040CIM3-2.5	2.500V	±0.5%, 100ppm/°C
LM4040DIM3-2.5	2.500V	±1.0%, 150ppm/°C
LM4040CIM3-4.1	4.096V	±0.5%, 100ppm/°C
LM4040DIM3-4.1	4.096V	±1.0%, 150ppm/°C
LM4040CIM3-5.0	5.000V	±0.5%, 100ppm/°C
LM4040DIM3-5.0	5.000V	±1.0%, 150ppm/°C

Part Number	Voltage	Accuracy, Temp. Coefficient
LM4041CIM3-1.2	1.225V	±0.5%, 100ppm/°C
LM4041DIM3-1.2	1.225V	±1.0%, 150ppm/°C
LM4041CIM3-ADJ	1.24V to 10V	±0.5%, 100ppm/°C
LM4041DIM3-ADJ	1.24V to 10V	±1.0%, 150ppm/°C

## SOT-23 Package Markings

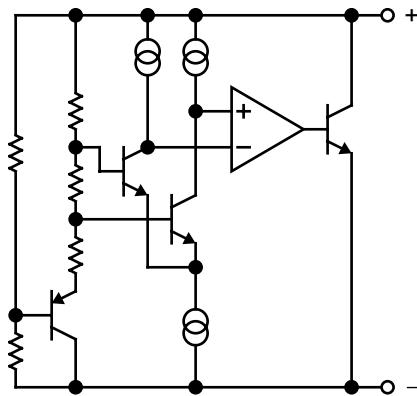
Example	Field	Code
R _ _	1st Character	R = Reference

**Example:** R2C represents *Reference, 2.500V, ±0.5%* (LM4040CIM3-2.5)

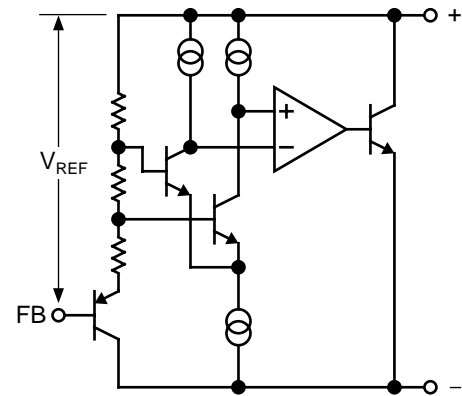
Example	Field	Code
_ 2 _	2nd Character	1 = 1.225V 2 = 2.500V 4 = 4.096V 5 = 5.000V A = Adjustable

Example	Field	Code
_ _ C	3rd Character	C = ±0.5% D = ±1.0%

**Note:** If 3rd character is omitted, container will indicate tolerance.



Functional Diagram  
LM4040, LM4041 Fixed



Functional Diagram  
LM4041 Adjustable

## Absolute Maximum Ratings

Reverse Current .....	20mA
Forward Current .....	10mA
Maximum Output Voltage	
LM4041-Adjustable .....	15V
Power Dissipation at $T_A = 25^\circ\text{C}$ ( <b>Note 2</b> ) .....	306mW
Storage Temperature .....	$-65^\circ\text{C}$ to $+150^\circ\text{C}$
Lead Temperature	
Vapor phase (60 seconds) .....	$+215^\circ\text{C}$
Infrared (15 seconds) .....	$+220^\circ\text{C}$
ESD Susceptibility	
Human Body Model ( <b>Note 3</b> ) .....	1kV
Machine Model ( <b>Note 3</b> ) .....	200V

## Operating Ratings (Notes 1 and 2)

Temperature Range	
( $T_{\text{MIN}} \leq T_A \leq T_{\text{MAX}}$ ) .....	$-40^\circ\text{C} \leq T_A \leq +85^\circ\text{C}$
Reverse Current	
LM4040-2.5 .....	60 $\mu\text{A}$ to 15mA
LM4040-4.1 .....	68 $\mu\text{A}$ to 15mA
LM4040-5.0 .....	74 $\mu\text{A}$ to 15mA
LM4041-1.2 .....	60 $\mu\text{A}$ to 12mA
LM4041-ADJ .....	60 $\mu\text{A}$ to 12mA
Output Voltage Range	
LM4041-ADJ .....	1.24V to 10V

- Note 1.** Absolute Maximum Ratings indicate limits beyond which damage to the device may occur. Operating Ratings indicate conditions for which the device is functional, but do not guarantee specific performance limits. For guaranteed specification and test conditions, see the "Electrical Characteristics". The guaranteed specifications apply only for the test conditions listed. Some performance characteristics may degrade when the device is not operated under the listed test conditions.
- Note 2.** The maximum power dissipation must be derated at elevated temperatures and is dictated by  $T_{\text{JMAX}}$  (maximum junction temperature),  $\theta_{\text{JA}}$  (junction to ambient thermal resistance), and  $T_A$  (ambient temperature). The maximum allowable power dissipation at any temperature is  $\text{PD}_{\text{MAX}} = (T_{\text{JMAX}} - T_A)/\theta_{\text{JA}}$  or the number given in the Absolute Maximum Ratings, whichever is lower. For the LM4040 and LM4041,  $T_{\text{JMAX}} = 125^\circ\text{C}$ , and the typical thermal resistance ( $\theta_{\text{JA}}$ ), when board mounted, is  $326^\circ\text{C}/\text{W}$  for the SOT-23 package.
- Note 3.** The human body model is a 100pF capacitor discharged through a 1.5k $\Omega$  resistor into each pin. The machine model is a 200pF capacitor discharged directly into each pin.

## LM4040-2.5 Electrical Characteristics (Note 4)

**Boldface limits apply for  $T_A = T_J = T_{MIN}$  to  $T_{MAX}$** ; all other limits  $T_A = T_J = 25^\circ\text{C}$ . The grades C and D designate initial Reverse Breakdown Voltage tolerance of  $\pm 0.5\%$  and  $\pm 1.0$  respectively.

Symbol	Parameter	Conditions	Typical (Note 5)	LM4040CIM3	LM4040DIM3	Units (Limit)
				Limits (Note 6)	Limits (Note 6)	
$V_R$	Reverse Breakdown Voltage	$I_R = 100\mu\text{A}$	2.500			V
	Reverse Breakdown Voltage Tolerance (Note 7)	$I_R = 100\mu\text{A}$		$\pm 12$ <b><math>\pm 29</math></b>	$\pm 25$ <b><math>\pm 49</math></b>	mV (max) mV (max)
$I_{RMIN}$	Minimum Operating Current		45	60 <b>65</b>	65 <b>70</b>	$\mu\text{A}$ $\mu\text{A}$ (max) $\mu\text{A}$ (max)
$\Delta V_R/\Delta T$	Average Reverse Breakdown Voltage Temperature Coefficient	$I_R = 10\text{mA}$ $I_R = 1\text{mA}$ $I_R = 100\mu\text{A}$	$\pm 20$ $\pm 15$ $\pm 15$	<b><math>\pm 100</math></b>	<b><math>\pm 150</math></b>	ppm/ $^\circ\text{C}$ ppm/ $^\circ\text{C}$ (max) ppm/ $^\circ\text{C}$ (max)
$\Delta V_R/\Delta I_R$	Reverse Breakdown Voltage Change with Operating Current Change	$I_{RMIN} \leq I_R \leq 1\text{mA}$	0.3	0.8 <b>1.0</b>	1.0 <b>1.2</b>	mV mV (max) mV (max)
		$1\text{mA} \leq I_R \leq 15\text{mA}$	2.5	6.0 <b>8.0</b>	8.0 <b>10.0</b>	mV mV (max) mV (max)
$Z_R$	Reverse Dynamic Impedance	$I_R = 1\text{mA}$ , $f = 120\text{Hz}$ $I_{AC} = 0.1 I_R$	0.3	0.9	1.1	$\Omega$ $\Omega$ (max)
$e_N$	Wideband Noise	$I_R = 100\mu\text{A}$ $10\text{Hz} \leq f \leq 10\text{kHz}$	35			$\mu\text{V}_{RMS}$
$\Delta V_R$	Reverse Breakdown Voltage Long Term Stability	$t = 1000\text{hrs}$ $T = 25^\circ\text{C} \pm 0.1^\circ\text{C}$ $I_R = 100\mu\text{A}$	120			ppm

**Note 4.** Specification for packaged product only.

**Note 5.** Typical values are at  $T_J = 25^\circ\text{C}$  and represent most likely parametric norm.

**Note 6.** Limits are 100% production tested at  $25^\circ\text{C}$ . Limits over temperature are guaranteed through correlation using Statistical Quality Control (SQL) methods.

**Note 7.** The boldface (over temperature limit for Reverse Breakdown Voltage Tolerance is defined as the room temperature Reverse Breakdown Voltage Tolerance  $\pm [(\Delta V_R/\Delta T)(65^\circ\text{C})(V_R)]$ .  $\Delta V_R/\Delta T$  is the  $V_R$  temperature coefficient,  $65^\circ\text{C}$  is the temperature range from  $-40^\circ\text{C}$  to the reference point of  $25^\circ\text{C}$ , and  $V_R$  is the reverse breakdown voltage. The total over temperature tolerance for the different grades follows:

C-grade:  $\pm 1.15\% = \pm 0.5\% \pm 100\text{ppm}/^\circ\text{C} \times 65^\circ\text{C}$

D-grade:  $\pm 1.98\% = \pm 1.0\% \pm 150\text{ppm}/^\circ\text{C} \times 65^\circ\text{C}$

Example: The C-grade LM4040-2.5 has an over temperature Reverse Breakdown Voltage tolerance of  $\pm 2.5 \times 1.15\% = \pm 29\text{mV}$ .

## LM4040-4.1 Electrical Characteristics (Note 4)

**Boldface limits apply for  $T_A = T_J = T_{MIN}$  to  $T_{MAX}$** ; all other limits  $T_A = T_J = 25^\circ\text{C}$ . The grades C and D designate initial Reverse Breakdown Voltage tolerance of  $\pm 0.5\%$  and  $\pm 1.0\%$  respectively.

Symbol	Parameter	Conditions	Typical (Note 5)	LM4040CIM3 Limits (Note 6)	LM4040DIM3 Limits (Note 6)	Units (Limits)
$V_R$	Reverse Breakdown Voltage	$I_R = 100\mu\text{A}$	4.096			V
	Reverse Breakdown Voltage Tolerance (Note 7)	$I_R = 100\mu\text{A}$		$\pm 20$ <b><math>\pm 47</math></b>	$\pm 41$ <b><math>\pm 81</math></b>	mV (max) mV (max)
$I_{RMIN}$	Minimum Operating Current		50	68 <b>73</b>	73 <b>78</b>	$\mu\text{A}$ $\mu\text{A}$ (max) $\mu\text{A}$ (max)
$\Delta V_R/\Delta T$	Average Reverse Breakdown Voltage Temperature Coefficient	$I_R = 10\text{mA}$ $I_R = 1\text{mA}$ $I_R = 100\mu\text{A}$	$\pm 30$ $\pm 20$ $\pm 20$	<b><math>\pm 100</math></b>	<b><math>\pm 150</math></b>	ppm/ $^\circ\text{C}$ ppm/ $^\circ\text{C}$ (max) ppm/ $^\circ\text{C}$ (max)
$\Delta V_R/\Delta I_R$	Reverse Breakdown Voltage Change with Operating Current Change	$I_{RMIN} \leq I_R \leq 1\text{mA}$	0.5	0.9 <b>1.2</b>	1.2 <b>1.5</b>	mV mV (max) mV (max)
		$1\text{mA} \leq I_R \leq 15\text{mA}$	3.0	7.0 <b>10.0</b>	9.0 <b>13.0</b>	mV mV (max) mV (max)
$Z_R$	Reverse Dynamic Impedance	$I_R = 1\text{mA}$ , $f = 120\text{Hz}$ $I_{AC} = 0.1 I_R$	0.5	1.0	1.3	$\Omega$ $\Omega$ (max)
$e_N$	Wideband Noise	$I_R = 100\mu\text{A}$ $10\text{Hz} \leq f \leq 10\text{kHz}$	80			$\mu\text{V}_{RMS}$
$\Delta V_R$	Reverse Breakdown Voltage Long Term Stability	$t = 1000\text{hrs}$ $T = 25^\circ\text{C} \pm 0.1^\circ\text{C}$ $I_R = 100\mu\text{A}$	120			ppm

**Note 4.** Specification for packaged product only.

**Note 5.** Typicals are at  $T_J = 25^\circ\text{C}$  and represent most likely parametric norm.

**Note 6.** Limits are 100% production tested at  $25^\circ\text{C}$ . Limits over temperature are guaranteed through correlation using Statistical Quality Control (SQL) methods.

**Note 7.** The boldface (over temperature limit for Reverse Breakdown Voltage Tolerance is defined as the room temperature Reverse Breakdown Voltage Tolerance  $\pm [(\Delta V_R/\Delta T)(65^\circ\text{C})(V_R)]$ .  $\Delta V_R/\Delta T$  is the  $V_R$  temperature coefficient,  $65^\circ\text{C}$  is the temperature range from  $-40^\circ\text{C}$  to the reference point of  $25^\circ\text{C}$ , and  $V_R$  is the reverse breakdown voltage. The total over temperature tolerance for the different grades follows:

C-grade:  $\pm 1.15\% = \pm 0.5\% \pm 100\text{ppm}/^\circ\text{C} \times 65^\circ\text{C}$

D-grade:  $\pm 1.98\% = \pm 1.0\% \pm 150\text{ppm}/^\circ\text{C} \times 65^\circ\text{C}$

Example: The C-grade LM4040-2.5 has an over temperature Reverse Breakdown Voltage tolerance of  $\pm 2.5 \times 1.15\% = \pm 29\text{mV}$ .

## LM4040-5.0 Electrical Characteristics (Note 4)

**Boldface limits apply for  $T_A = T_J = T_{MIN}$  to  $T_{MAX}$** ; all other limits  $T_A = T_J = 25^\circ\text{C}$ . The grades C and D designate initial Reverse Breakdown Voltage tolerance of  $\pm 0.5\%$  and  $\pm 1.0\%$  respectively.

Symbol	Parameter	Conditions	Typical (Note 5)	LM4040CIM3	LM4040DIM3	Units (Limits)
				Limits (Note 6)	Limits (Note 6)	
$V_R$	Reverse Breakdown Voltage	$I_R = 100\mu\text{A}$	5.000			V
	Reverse Breakdown Voltage Tolerance (Note 7)	$I_R = 100\mu\text{A}$		$\pm 25$ <b><math>\pm 58</math></b>	$\pm 50$ <b><math>\pm 99</math></b>	mV (max) mV (max)
$I_{RMIN}$	Minimum Operating Current		54	74 <b>80</b>	79 <b>85</b>	$\mu\text{A}$ $\mu\text{A}$ (max) $\mu\text{A}$ (max)
$\Delta V_R/\Delta T$	Average Reverse Breakdown Voltage Temperature Coefficient	$I_R = 10\text{mA}$ $I_R = 1\text{mA}$ $I_R = 100\mu\text{A}$	$\pm 30$ $\pm 20$ $\pm 20$	<b><math>\pm 100</math></b>	<b><math>\pm 150</math></b>	ppm/ $^\circ\text{C}$ ppm/ $^\circ\text{C}$ (max) ppm/ $^\circ\text{C}$ (max)
$\Delta V_R/\Delta I_R$	Reverse Breakdown Voltage Change with Operating Current Change	$I_{RMIN} \leq I_R \leq 1\text{mA}$	0.5	1.0 <b>1.4</b>	1.3 <b>1.8</b>	mV mV (max) mV (max)
		$1\text{mA} \leq I_R \leq 15\text{mA}$	3.5	8.0 <b>12.0</b>	10.0 <b>15.0</b>	mV mV (max) mV (max)
$Z_R$	Reverse Dynamic Impedance	$I_R = 1\text{mA}$ , $f = 120\text{Hz}$ $I_{AC} = 0.1 I_R$	0.5	1.1	1.5	$\Omega$ $\Omega$ (max)
$e_N$	Wideband Noise	$I_R = 100\mu\text{A}$ $10\text{Hz} \leq f \leq 10\text{kHz}$	80			$\mu\text{V}_{RMS}$
$\Delta V_R$	Reverse Breakdown Voltage Long Term Stability	$t = 1000\text{hrs}$ $T = 25^\circ\text{C} \pm 0.1^\circ\text{C}$ $I_R = 100\mu\text{A}$	120			ppm

**Note 4.** Specification for packaged product only.

**Note 5.** Typicals are at  $T_J = 25^\circ\text{C}$  and represent most likely parametric norm.

**Note 6.** Limits are 100% production tested at  $25^\circ\text{C}$ . Limits over temperature are guaranteed through correlation using Statistical Quality Control (SQL) methods.

**Note 7.** The boldface (over temperature limit for Reverse Breakdown Voltage Tolerance is defined as the room temperature Reverse Breakdown Voltage Tolerance  $\pm[(\Delta V_R/\Delta T)(65^\circ\text{C})(V_R)]$ .  $\Delta V_R/\Delta T$  is the  $V_R$  temperature coefficient,  $65^\circ\text{C}$  is the temperature range from  $-40^\circ\text{C}$  to the reference point of  $25^\circ\text{C}$ , and  $V_R$  is the reverse breakdown voltage. The total over temperature tolerance for the different grades follows:

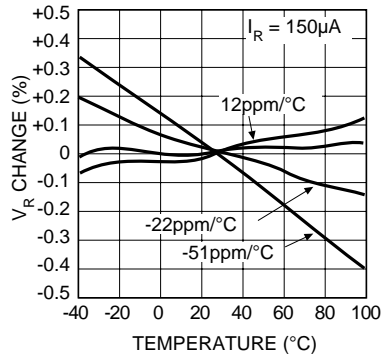
C-grade:  $\pm 1.15\% = \pm 0.5\% \pm 100\text{ppm}/^\circ\text{C} \times 65^\circ\text{C}$

D-grade:  $\pm 1.98\% = \pm 1.0\% \pm 150\text{ppm}/^\circ\text{C} \times 65^\circ\text{C}$

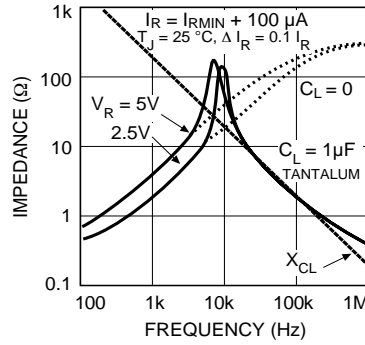
Example: The C-grade LM4040-2.5 has an over temperature Reverse Breakdown Voltage tolerance of  $\pm 2.5 \times 1.15\% = \pm 29\text{mV}$ .

# LM4040 Typical Characteristics

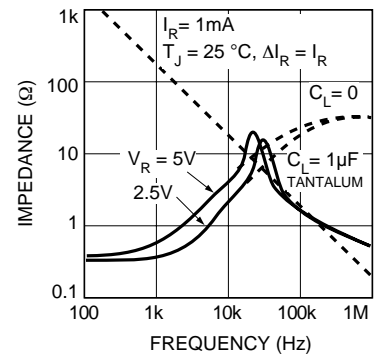
**Temperature Drift for Different Average Temperature Coefficient**



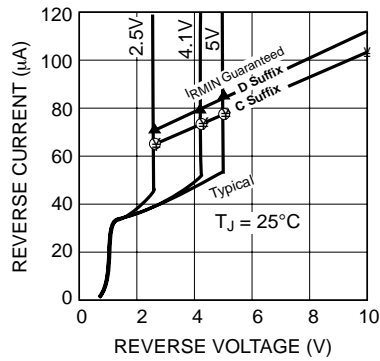
**Output Impedance vs. Frequency**



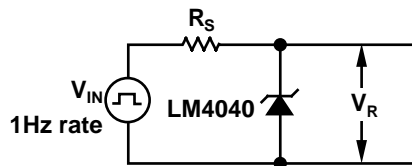
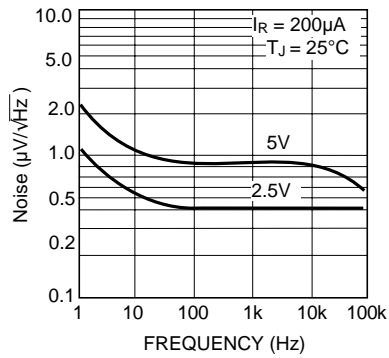
**Output Impedance vs. Frequency**



**Reverse Characteristics and Minimum Operating Current**

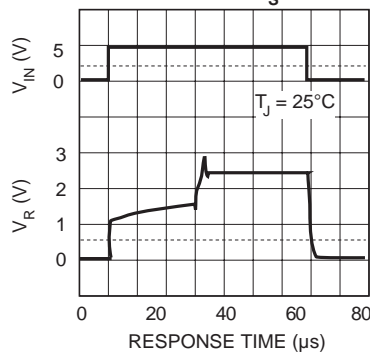


**Noise Voltage vs. Frequency**

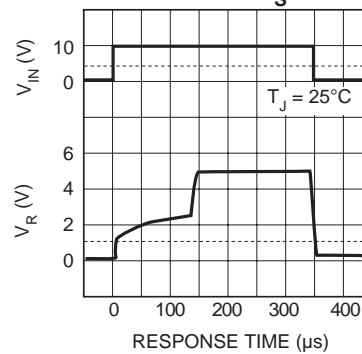


**Test Circuit**

**Start-up Characteristics LM4040-2.5 R\_S = 30k**



**Start-up Characteristics LM4040-5.0 R\_S = 30k**



## LM4041-1.2 Electrical Characteristics (Note 4)

**Boldface limits apply for  $T_A = T_J = T_{MIN}$  to  $T_{MAX}$** ; all other limits  $T_A = T_J = 25^\circ\text{C}$ . The grades C and D designate initial Reverse Breakdown Voltage tolerance of  $\pm 0.5\%$  and  $\pm 1.0\%$ , respectively.

Symbol	Parameter	Conditions	Typical (Note 5)	LM4041CIM3	
				Limits (Note 6)	Units (Limit)
$V_R$	Reverse Breakdown Voltage	$I_R = 100\mu\text{A}$	1.225		V
	Reverse Breakdown Voltage Tolerance (Note 7)	$I_R = 100\mu\text{A}$		$\pm 6$ <b><math>\pm 14</math></b>	mV (max) mV (max)
$I_{RMIN}$	Minimum Operating Current		45	60 <b>65</b>	$\mu\text{A}$ $\mu\text{A}$ (max) $\mu\text{A}$ (max)
$\Delta V_R/\Delta T$	Average Reverse Breakdown Voltage Temperature Coefficient	$I_R = 10\text{mA}$ $I_R = 1\text{mA}$ $I_R = 100\mu\text{A}$	$\pm 20$ $\pm 15$ $\pm 15$	<b><math>\pm 100</math></b>	ppm/ $^\circ\text{C}$ ppm/ $^\circ\text{C}$ (max) ppm/ $^\circ\text{C}$ (max)
$\Delta V_R/\Delta I_R$	Reverse Breakdown Voltage Change with Operating Current Change	$I_{RMIN} \leq I_R \leq 1\text{mA}$	0.7	1.5 <b>2.0</b>	mV mV (max) mV (max)
		$1\text{mA} \leq I_R \leq 15\text{mA}$	4.0	6.0 <b>8.0</b>	mV mV (max) mV (max)
$Z_R$	Reverse Dynamic Impedance	$I_R = 1\text{mA}$ , $f = 120\text{Hz}$ $I_{AC} = 0.1 I_R$	0.5	1.5	$\Omega$ $\Omega$ (max)
$e_N$	Wideband Noise	$I_R = 100\mu\text{A}$ $10\text{Hz} \leq f \leq 10\text{kHz}$	20		$\mu\text{V}_{RMS}$
$\Delta V_R$	Reverse Breakdown Voltage Long Term Stability	$t = 1000\text{hrs}$ $T = 25^\circ\text{C} \pm 0.1^\circ\text{C}$ $I_R = 100\mu\text{A}$	120		ppm

**Note 4.** Specification for packaged product only.

**Note 5.** Typicals are at  $T_J = 25^\circ\text{C}$  and represent most likely parametric norm.

**Note 6.** Limits are 100% production tested at  $25^\circ\text{C}$ . Limits over temperature are guaranteed through correlation using Statistical Quality Control (SQL) methods.

**Note 7.** The boldface (over temperature limit for Reverse Breakdown Voltage Tolerance is defined as the room temperature Reverse Breakdown Voltage Tolerance  $\pm[(\Delta V_R/\Delta T)(65^\circ\text{C})(V_R)]$ .  $\Delta V_R/\Delta T$  is the  $V_R$  temperature coefficient,  $65^\circ\text{C}$  is the temperature range from  $-40^\circ\text{C}$  to the reference point of  $25^\circ\text{C}$ , and  $V_R$  is the reverse breakdown voltage. The total over temperature tolerance for the different grades follows:

C-grade:  $\pm 1.15\% = \pm 0.5\% \pm 100\text{ppm}/^\circ\text{C} \times 65^\circ\text{C}$

D-grade:  $\pm 1.98\% = \pm 1.0\% \pm 150\text{ppm}/^\circ\text{C} \times 65^\circ\text{C}$

Example: The C-grade LM4040-2.5 has an over temperature Reverse Breakdown Voltage tolerance of  $\pm 2.5 \times 1.15\% = \pm 29\text{mV}$ .



## LM4041-1.2 Electrical Characteristics (Note 4)

**Boldface limits apply for  $T_A = T_J = T_{MIN}$  to  $T_{MAX}$** ; all other limits  $T_A = T_J = 25^\circ\text{C}$ . The grades C and D designate initial Reverse Breakdown Voltage tolerance of  $\pm 0.5\%$  and  $\pm 1.0\%$ , respectively.

Symbol	Parameter	Conditions	Typical (Note 5)	LM4041DIM3 Limits (Note 6)	Units (Limit)
$V_R$	Reverse Breakdown Voltage	$I_R = 100\mu\text{A}$	1.225		V
	Reverse Breakdown Voltage Tolerance (Note 7)	$I_R = 100\mu\text{A}$		$\pm 12$ <b><math>\pm 24</math></b>	mV (max) mV (max)
$I_{RMIN}$	Minimum Operating Current		45	65 <b>70</b>	$\mu\text{A}$ $\mu\text{A}$ (max) $\mu\text{A}$ (max)
$\Delta V_R/\Delta T$	Average Reverse Breakdown Voltage Temperature Coefficient	$I_R = 10\text{mA}$ $I_R = 1\text{mA}$ $I_R = 100\mu\text{A}$	$\pm 20$ $\pm 15$ $\pm 15$	<b><math>\pm 150</math></b>	ppm/ $^\circ\text{C}$ ppm/ $^\circ\text{C}$ (max) ppm/ $^\circ\text{C}$ (max)
$\Delta V_R/\Delta I_R$	Reverse Breakdown Voltage Change with Operating Current Change	$I_{RMIN} \leq I_R \leq 1\text{mA}$	0.7	2.0 <b>2.5</b>	mV mV (max) mV (max)
		$1\text{mA} \leq I_R \leq 15\text{mA}$	2.5	8.0 <b>10.0</b>	mV mV (max) mV (max)
$Z_R$	Reverse Dynamic Impedance	$I_R = 1\text{mA}$ , $f = 120\text{Hz}$ $I_{AC} = 0.1 I_R$	0.5	2.0	$\Omega$ $\Omega$ (max)
$e_N$	Wideband Noise	$I_R = 100\mu\text{A}$ $10\text{Hz} \leq f \leq 10\text{kHz}$	20		$\mu\text{V}_{RMS}$
$\Delta V_R$	Reverse Breakdown Voltage Long Term Stability	$t = 1000\text{hrs}$ $T = 25^\circ\text{C} \pm 0.1^\circ\text{C}$ $I_R = 100\mu\text{A}$	120		ppm

**Note 4.** Specification for packaged product only.

**Note 5.** Typicals are at  $T_J = 25^\circ\text{C}$  and represent most likely parametric norm.

**Note 6.** Limits are 100% production tested at  $25^\circ\text{C}$ . Limits over temperature are guaranteed through correlation using Statistical Quality Control (SQL) methods.

**Note 7.** The boldface (over temperature limit for Reverse Breakdown Voltage Tolerance is defined as the room temperature Reverse Breakdown Voltage Tolerance  $\pm[(\Delta V_R/\Delta T)(65^\circ\text{C})(V_R)]$ .  $\Delta V_R/\Delta T$  is the  $V_R$  temperature coefficient,  $65^\circ\text{C}$  is the temperature range from  $-40^\circ\text{C}$  to the reference point of  $25^\circ\text{C}$ , and  $V_R$  is the reverse breakdown voltage. The total over temperature tolerance for the different grades follows:

C-grade:  $\pm 1.15\% = \pm 0.5\% \pm 100\text{ppm}/^\circ\text{C} \times 65^\circ\text{C}$

D-grade:  $\pm 1.98\% = \pm 1.0\% \pm 150\text{ppm}/^\circ\text{C} \times 65^\circ\text{C}$

Example: The C-grade LM4040-2.5 has an over temperature Reverse Breakdown Voltage tolerance of  $\pm 2.5 \times 1.15\% = \pm 29\text{mV}$ .

## LM4041-Adjustable Electrical Characteristics (Note 4)

**Boldface limits apply for  $T_A = T_J = T_{MIN}$  to  $T_{MAX}$ :** all other limits  $T_J = 25^\circ\text{C}$  unless otherwise specified (SOT-23, see Note 8),  $I_{RMIN} \leq I_R < 12\text{mA}$ ,  $V_{REF} \leq V_{OUT} \leq 10\text{V}$ . The grades C and D designate initial Reverse Breakdown Voltage tolerance of  $\pm 0.5\%$  and  $\pm 1\%$ , respectively for  $V_{OUT} = 5\text{V}$ .

Symbol	Parameter	Conditions	Typical (Note 5)	LM4041CIM3  Limits (Note 6)	LM4041DIM3  Limits (Note 6)	Units (Limit)
$V_{REF}$	Reference Breakdown Voltage	$I_R = 100\mu\text{A}$ $V_{OUT} = 5\text{V}$	1.233			V
	Reference Breakdown Voltage Tolerance (Note 9)	$I_R = 100\mu\text{A}$		$\pm 6.2$ <b><math>\pm 14</math></b>	$\pm 12$ <b><math>\pm 24</math></b>	mV (max) mV (max)
$I_{RMIN}$	Minimum Operating Current		45	60 <b>65</b>	65 <b>70</b>	$\mu\text{A}$ $\mu\text{A}$ (max) $\mu\text{A}$ (max)
$\Delta V_{REF}/\Delta I_R$	Reference Voltage Change with Operating Current Change	$I_{RMIN} \leq I_R$ 1mA SOT-23: $V_{OUT} \geq 1.6\text{V}$ (Note 8)	0.7	1.5 <b>2.0</b>	2.0 <b>2.5</b>	mV mV (max) mV (max)
		$1\text{mA} \leq I_R$ 15mA SOT-23: $V_{OUT} \geq 1.6\text{V}$ (Note 8)	2	4 <b>6</b>	6 <b>8</b>	mV mV (max) mV (max)
$\Delta V_{REF}/\Delta V_O$	Reference Voltage Change with Output Voltage Change	$I_R = 1\text{mA}$	-1.55	-2.0 <b>-2.5</b>	-2.5 <b>-3.0</b>	mV/V mV/V (max) mV/V (max)
$I_{FB}$	Feedback Current		60	100 <b>120</b>	150 <b>200</b>	nA nA (max) nA (max)
$\Delta V_{REF}/\Delta T$	Average Reference Voltage Temperature Coefficient (Note 9)	$V_{OUT} = 5\text{V}$ $I_R = 10\text{mA}$ $I_R = 1\text{mA}$ $I_R = 100\mu\text{A}$	$\pm 20$ $\pm 15$ $\pm 15$	<b><math>\pm 100</math></b>	<b><math>\pm 150</math></b>	ppm/ $^\circ\text{C}$ ppm/ $^\circ\text{C}$ (max) ppm/ $^\circ\text{C}$ (max)
$Z_{OUT}$	Dynamic Output Impedance	$I_R = 1\text{mA}$ , $f = 120\text{Hz}$ $I_{AC} = 0.1 I_R$ $V_{OUT} = V_{REF}$ $V_{OUT} = 10\text{V}$	0.3 2			$\Omega$ $\Omega$ (max)
$e_N$	Wideband Noise	$I_R = 100\mu\text{A}$ $10\text{Hz} \leq f \leq 10\text{kHz}$	20			$\mu\text{V}_{RMS}$
$\Delta V_{REF}$	Reference Voltage Long Term Stability	$t = 1000\text{hrs}$ $T = 25^\circ\text{C} \pm 0.1^\circ\text{C}$ $I_R = 100\mu\text{A}$	120			ppm

**Note 4.** Specification for packaged product only.

**Note 5.** Typical values are at  $T_J = 25^\circ\text{C}$  and represent most likely parametric norm.

**Note 6.** Limits are 100% production tested at  $25^\circ\text{C}$ . Limits over temperature are guaranteed through correlation using Statistical Quality Control (SQL) methods.

**Note 7.** The boldface (over temperature limit for Reverse Breakdown Voltage Tolerance is defined as the room temperature Reverse Breakdown Voltage Tolerance  $\pm[(\Delta V_R/\Delta T)(65^\circ\text{C})(V_R)]$ .  $\Delta V_R/\Delta T$  is the  $V_R$  temperature coefficient,  $65^\circ\text{C}$  is the temperature range from  $-40^\circ\text{C}$  to the reference point of  $25^\circ\text{C}$ , and  $V_R$  is the reverse breakdown voltage. The total over temperature tolerance for the different grades follows:

C-grade:  $\pm 1.15\% = \pm 0.5\% \pm 100\text{ppm}/^\circ\text{C} \times 65^\circ\text{C}$

D-grade:  $\pm 1.98\% = \pm 1.0\% \pm 150\text{ppm}/^\circ\text{C} \times 65^\circ\text{C}$

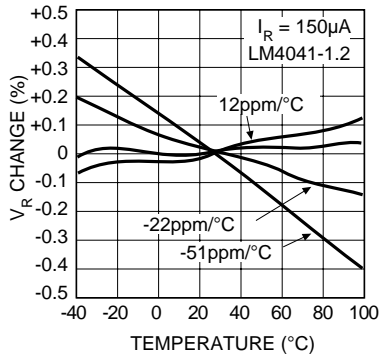
Example: The C-grade LM4040-2.5 has an over temperature Reverse Breakdown Voltage tolerance of  $\pm 2.5 \times 1.15\% = \pm 29\text{mV}$ .

**Note 8.** When  $V_{OUT} \leq 1.6\text{V}$ , the LM4041-ADJ must operate at reduced  $I_R$ . This is caused by the series resistance of the die attach between the die (-) output and the package (-) output pin. See the Output Saturation curve in the "Typical Performance Characteristics" section.

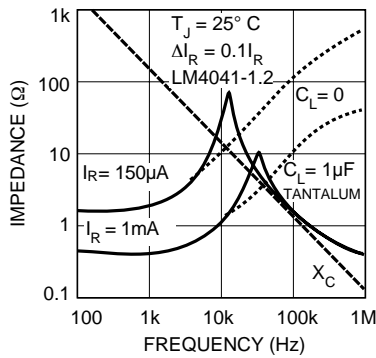
**Note 9.** Reference voltage and temperature coefficient will change with output voltage. See "Typical Performance Characteristics" curves.

# LM4041 Typical Characteristics

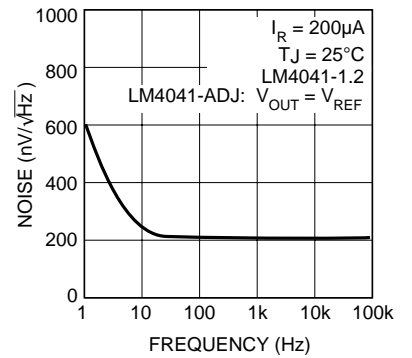
**Temperature Drift for Different Average Temperature Coefficient**



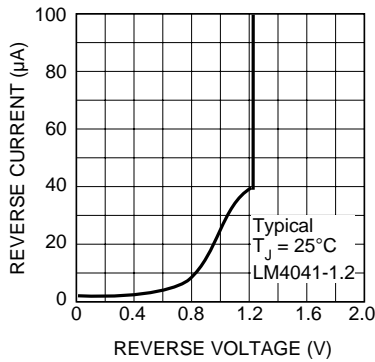
**Output Impedance vs. Frequency**



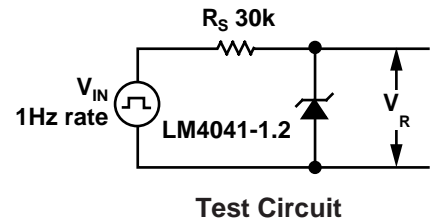
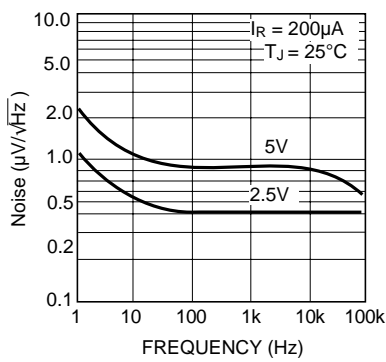
**Voltage Impedance**



**Reverse Characteristics and Minimum Operating Current**

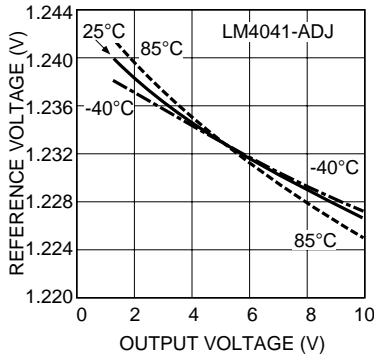


**Noise Voltage vs. Frequency**

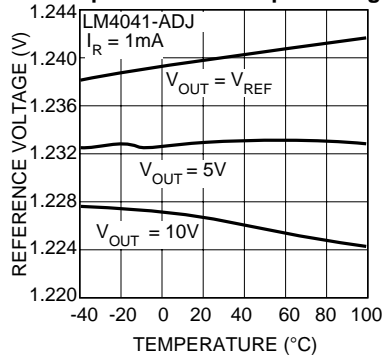


# LM4041 Typical Characteristics

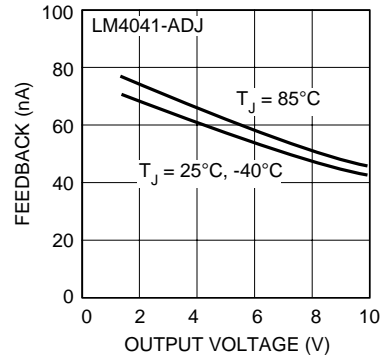
**Reference Voltage vs. Output Voltage and Temperature**



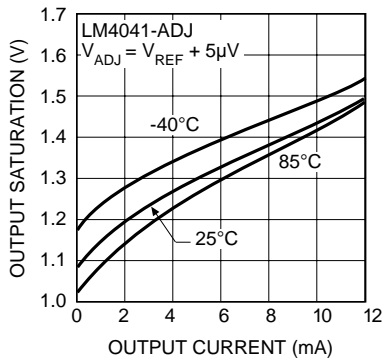
**Reference Voltage vs. Temperature and Output Voltage**



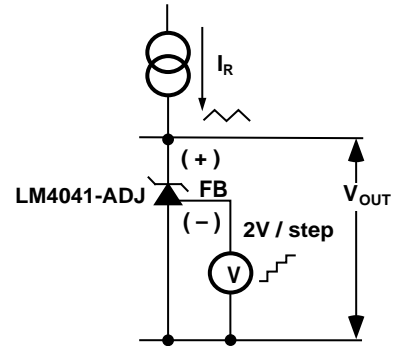
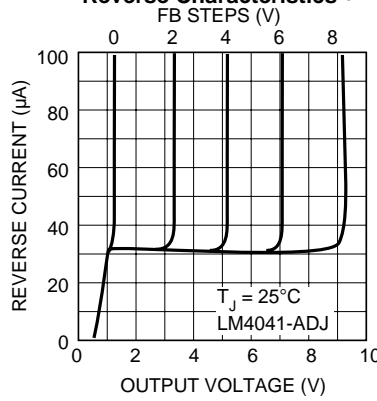
**Feedback Current vs. Output Voltage and Temperature**



**Output Saturation**

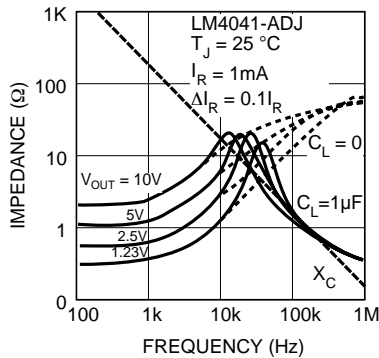


**Reverse Characteristics †**

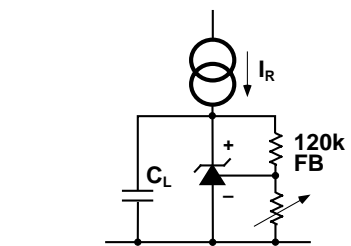
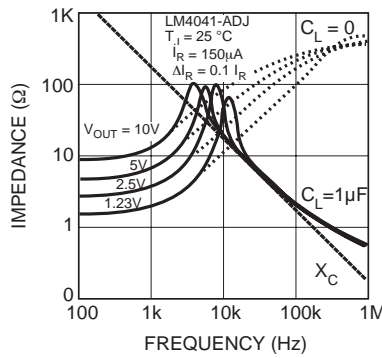


**† Reverse Characteristics Test Circuit**

**Output Impedance vs. Frequency \***

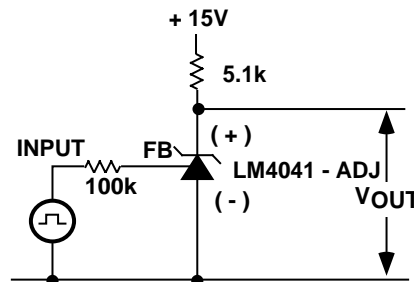
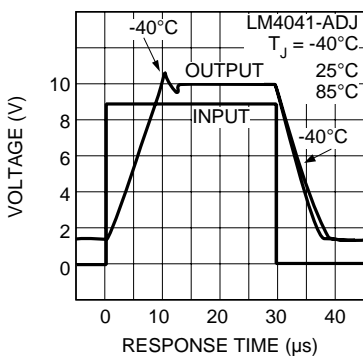


**Output Impedance vs. Frequency \***



**\* Output Impedance vs. Freq. Test Circuit**

**Large Signal Response ‡**



**‡ Large Signal Response Test Circuit**

\* Output impedance measurement.  
 † Reverse characteristics measurement.  
 ‡ Large signal response measurement.

## Applications Information

The stable operation of the LM4040 and LM4041 references requires an external capacitor greater than 10nF connected between the (+) and (-) pins. Bypass capacitors with values between 100pF and 10nF have been found to cause the devices to exhibit instabilities.

### Schottky Diode

LM4040-x.x and LM4041-1.2 in the SOT-23 package have a parasitic Schottky diode between pin 2 (-) and pin 3 (die attach interface connect). Pin 3 of the SOT-23 package must float or be connected to pin 2. LM4041-ADJs use pin 3 as the (-) output.

### Conventional Shunt Regulator

In a conventional shunt regulator application (see Figure 1), an external series resistor ( $R_S$ ) is connected between the supply voltage and the LM4040-x.x or LM4041-1.2 reference.  $R_S$  determines the current that flows through the load ( $I_L$ ) and the reference ( $I_Q$ ). Since load current and supply voltage may vary,  $R_S$  should be small enough to supply at least the minimum acceptable  $I_Q$  to the reference even when the supply voltage is at its minimum and the load current is at its maximum value. When the supply voltage is at its maximum and  $I_L$  is at its minimum,  $R_S$  should be large enough so that the current flowing through the LM4040-x.x is less than 15mA, and the current flowing through the LM4041-1.2 or LM4041-ADJ is less than 12mA.

$R_S$  is determined by the supply voltage ( $V_S$ ), the load and operating current, ( $I_L$  and  $I_Q$ ), and the reference's reverse breakdown voltage ( $V_R$ ):

$$R_S = (V_S - V_R) / (I_L + I_Q)$$

## Typical Application Circuits

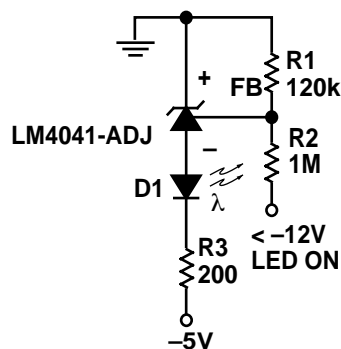


Figure 3. Voltage Level Detector

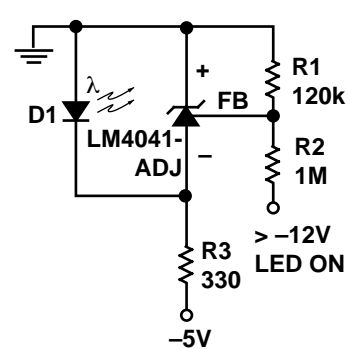


Figure 4. Voltage Level Detector

## Adjustable Regulator

The LM4041-ADJ's output voltage can be adjusted to any value in the range of 1.24V through 10V. It is a function of the internal reference voltage ( $V_{REF}$ ) and the ratio of the external feedback resistors as shown in Figure 2. The output is found using the equation:

$$(1) \quad V_O = V_{REF} [ (R_2/R_1) + 1 ]$$

where  $V_O$  is the desired output voltage. The actual value of the internal  $V_{REF}$  is a function of  $V_O$ . The "corrected"  $V_{REF}$  is determined by:

$$(2) \quad V_{REF}' = V_O (\Delta V_{REF} / \Delta V_O) + V_Y$$

where  $V_O$  is the desired output voltage.  $\Delta V_{REF} / \Delta V_O$  is found in the "Electrical Characteristics" and is typically  $-1.3\text{mV/V}$  and  $V_Y$  is equal to 1.233V. Replace the value of  $V_{REF}$  in equation (1) with the value  $V_{REF}'$  found using equation (2).

Note that actual output voltage can deviate from that predicted using the typical  $\Delta V_{REF} / \Delta V_O$  in equation (2); for C-grade parts, the worst-case  $\Delta V_{REF} / \Delta V_O$  is  $-2.5\text{mV/V}$  and  $V_Y = 1.248\text{V}$ .

The following example shows the difference in output voltage resulting from the typical and worst case values of  $\Delta V_{REF} / \Delta V_O$ .

Let  $V_O = +9\text{V}$ . Using the typical values of  $\Delta V_{REF} / \Delta V_O$ ,  $V_{REF}$  is 1.223V. Choosing a value of  $R_1 = 10\text{k}\Omega$ ,  $R_2 = 63.272\text{k}\Omega$ . Using the worst case  $\Delta V_{REF} / \Delta V_O$  for the C-grade and D-grade parts, the output voltage is actually 8.965V and 8.946V respectively. This results in possible errors as large as 0.39% for the C-grade parts and 0.59% for the D-grade parts. Once again, resistor values found using the typical value of  $\Delta V_{REF} / \Delta V_O$  will work in most cases, requiring no further adjustment.

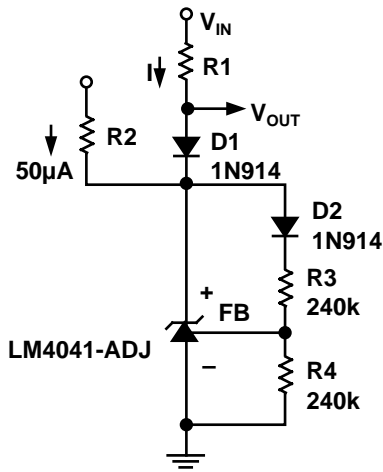


Figure 5. Fast Positive Clamp  
 $2.4V + \Delta V_{D1}$

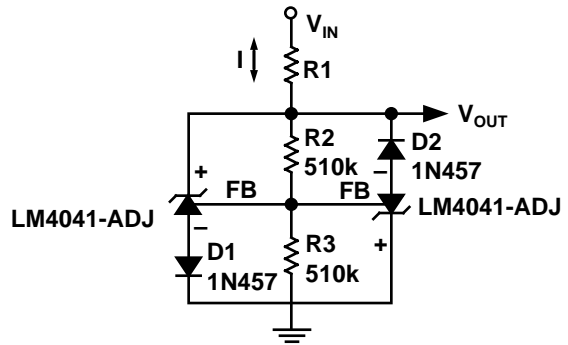


Figure 6. Bidirectional Clamp  
 $\pm 2.4V$

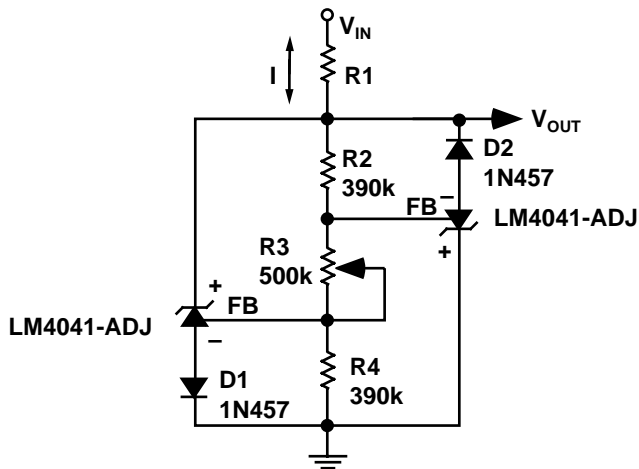


Figure 7. Bidirectional Adjustable Clamp  
 $\pm 18V$  to  $\pm 2.4V$

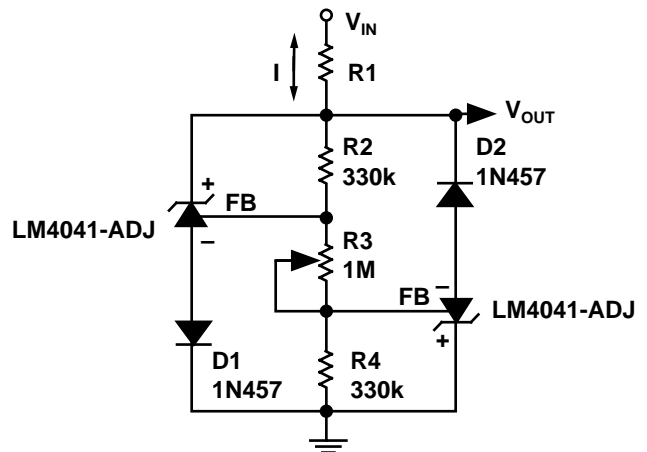
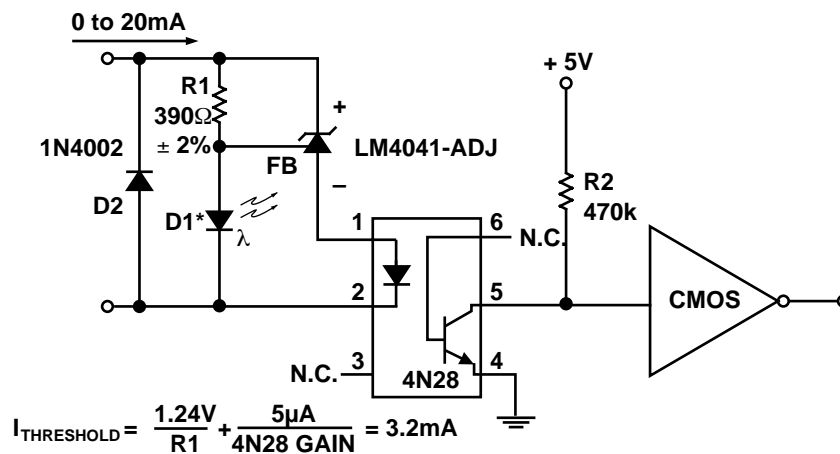


Figure 8. Bidirectional Adjustable Clamp  
 $\pm 2.4$  to  $\pm 6V$



\* D1 can be any LED,  $V_F = 1.5V$  to  $2.2V$  at  $3mA$ . D1 may act as an indicator. D1 will be on if  $I_{THRESHOLD}$  falls below the threshold current, except with  $I = 0$ .

Figure 9. Floating Current Detector

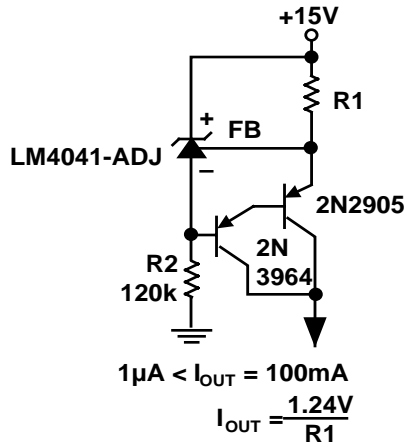
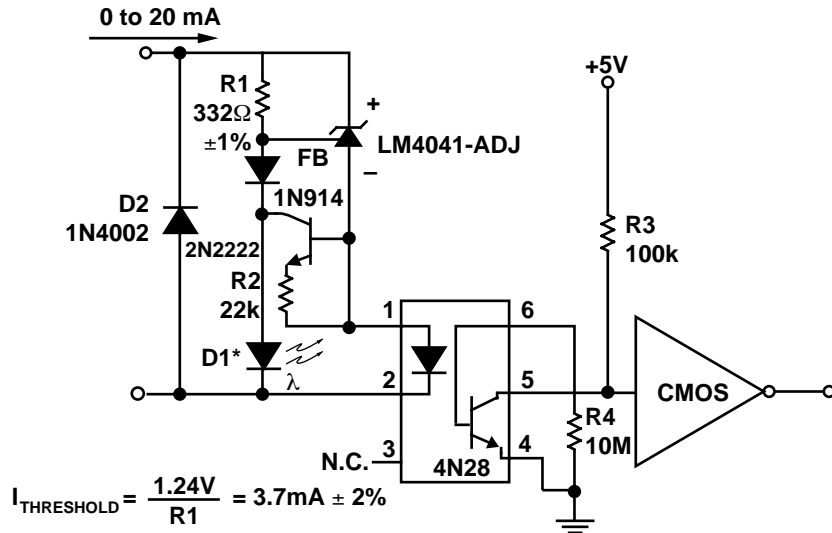


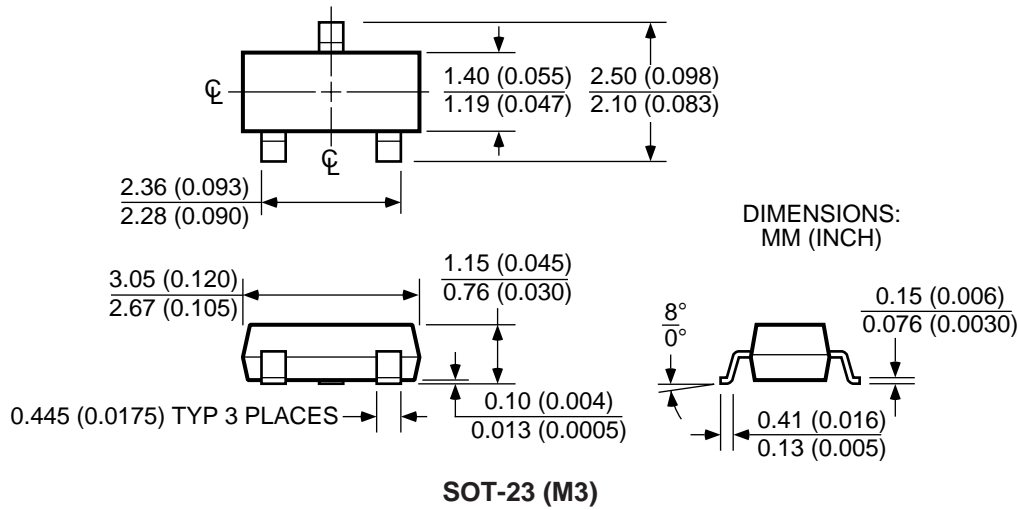
Figure 10. Current Source



\* D1 can be any LED,  $V_F = 1.5\text{V}$  to  $2.2\text{V}$  at  $3\text{mA}$ . D1 may act as an indicator. D1 will be on if  $I_{\text{THRESHOLD}}$  falls below the threshold current, except with  $I = 0$ .

Figure 11. Precision Floating Current Detector

## Package Information



**MICREL, INC. 1849 FORTUNE DRIVE SAN JOSE, CA 95131 USA**

TEL + 1 (408) 944-0800 FAX + 1 (408) 944-0970 WEB <http://www.micrel.com>

The information furnished by Micrel in this datasheet is believed to be accurate and reliable. However, no responsibility is assumed by Micrel for its use. Micrel reserves the right to change circuitry and specifications at any time without notification to the customer.

Micrel Products are not designed or authorized for use as components in life support appliances, devices or systems where malfunction of a product can reasonably be expected to result in personal injury. Life support devices or systems are devices or systems that (a) are intended for surgical implant into the body or (b) support or sustain life, and whose failure to perform can be reasonably expected to result in a significant injury to the user. A Purchaser's use or sale of Micrel Products for use in life support appliances, devices or systems is at Purchaser's own risk and Purchaser agrees to fully indemnify Micrel for any damages resulting from such use or sale.

© 2003 Micrel, Incorporated.